

RELEASE

DATE:

COMPANY:

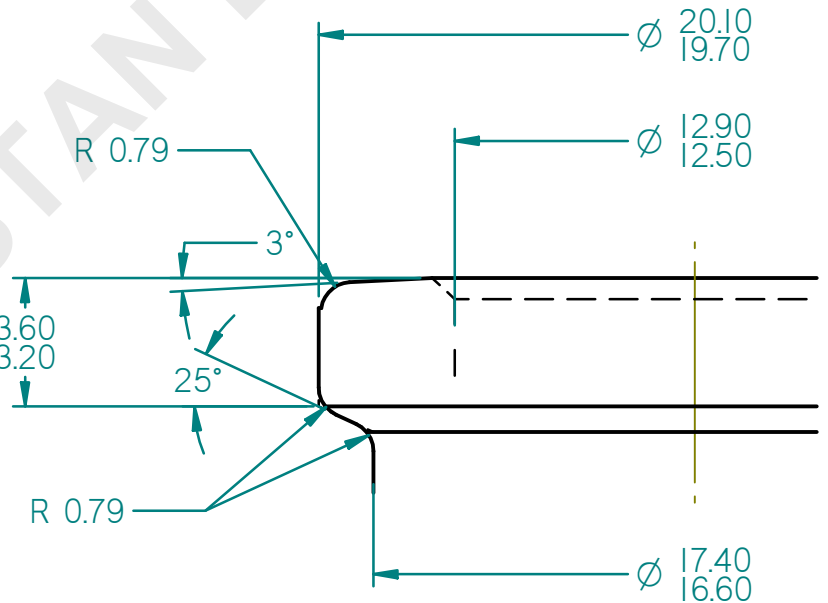
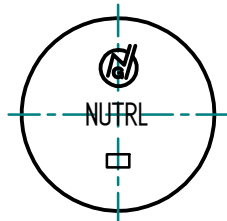
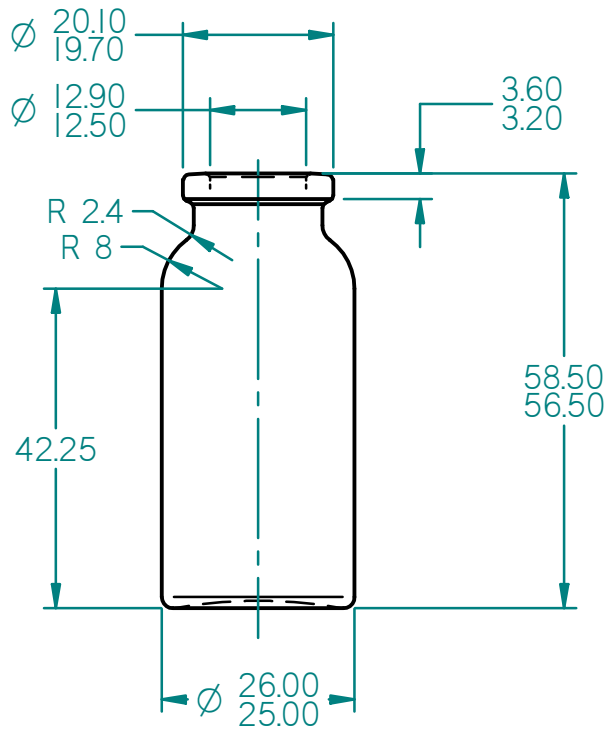

FINISH : 20 mm STD.

Protective note ISO 16016 observed

GENERAL TOLERANCES DIN 6129-1 (DIMENSIONS WITHOUT TOLERANCES ARE FOR REFERENCE ONLY)				FINISH: 20 mm STD.		O'FLOW CAPACITY: 16.50 - 17.50 ml		ARTICLE NO.:				
				FINISH DWG: NA		WEIGHT: 23 g Approx.		5152200100		TITLE: <h1>15 ml EROS - N</h1>		
				FINISH MOLD NO: 910		TYPE OF GLASS: I COLOUR: FLINT						
				DATE	NAME							
				DRAWN	21/11/2013		Paresh					
				CHECKED	21/11/2013		H.B.P.					
				SCALE	1 : 1, 5 : 1							
				GERRESHEIMER NEUTRAL GLASS & ALLIED INDS. PVT. LTD. MUMBAI / KOSAMBA		MOLD NO.:	DRAWING NO.:		REVISION	SHEET	FORMAT	
						108	B 2200		0	1 OF 1	A4	
REV.				CHANGE	DATE	NAME		FILE: 15 ml EROS - N.dft				